

OPERATING INSTRUCTIONS
AND
SPARE PARTS LIST

Villiers

Mark 10 & Mark 12
FOUR-STROKE ENGINES

TWO SHILLINGS
AND SIXPENCE

THE VILLIERS ENGINEERING CO. LTD.
WOLVERHAMPTON, ENGLAND

CONTENTS

(See also Inside Back Cover)

	Page
Air Filter	6, 15
Camshaft	11
Carburettors	12 to 15
Connecting Rod	10
Contact Breaker, Adjustment	8, 15
Cooling System	11
Crankshaft and Camshaft	11
Decarbonising	8
Engine Data	3
Estimates for Overhaul	36
Governor	9
Guarantee	38
Installation	4
Leaks, Oil	12
Lubrication	4, 6
Maintenance and Repairs	8
Magneto Timing	9
Petrol/Vaporising Oil Engines	5
Petrol Filter	8
Piston Rings	11
Reduction Gears	7
Routine Attention	6
Starting	4
Service and Repair Organisation	36, 37
Sparking Plug	8
Stopping... ..	5
Tracing Troubles	35
Valve, Clearances	9
Valve, Grinding	8
Valve, Timing	11

(see inside Back Cover for Illustrations & Spare Parts Lists)

OPERATING INSTRUCTIONS
FOR

Villiers

Mark 10 & Mark 12 ENGINES

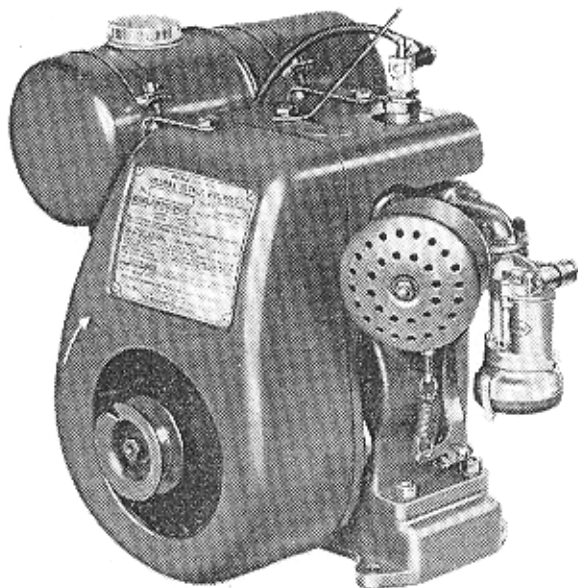

BEFORE STARTING THIS ENGINE FOR THE
FIRST TIME CAREFULLY READ PAGES 4 AND 5

Introduction



YOUR Villiers engine is the heart of the machine in which it is installed. It has been manufactured and assembled with great care and precision, and it will give you long and efficient service if it receives the attention it deserves.

This book contains the necessary information to enable you to give your engine this simple, but important routine attention, and you will be well advised to keep the book on hand for consultation when necessary.

After a long period of service, your engine may require overhauling, and it is important always to make sure that only genuine Villiers replacement parts are used. Remember that genuine Villiers spares are made with the same fine workmanship as the original engine components. If you do not know the name of your nearest Service Depot for Villiers engines, write for information to the manufacturers:—

THE VILLIERS ENGINEERING COMPANY LTD.
Marston Road - - - - - Wolverhampton

TELEPHONES :—22399 (20 lines)
CODE:—BENTLEY'S.

TELEGRAMS :—VILLIERS,
WOLVERHAMPTON.

ENGINE DATA

Engine	Villiers Mark 10 and 12, and Mark 10 H.S. and 12 H.S.
Bore	{ 50 mm. (Mark 10). 55 mm. (Mark 12).
Stroke	50 mm.
Capacity	{ 98 c.c. (Mark 10) 120 c.c. (Mark 12)
Power Output—Continuous Running	
Mark 10	1.3 b.h.p. @ 2,800 r.p.m.
Mark 10 H.S.	1.6 b.h.p. @ 3,400 r.p.m.
Mark 12	1.5 b.h.p. @ 2,800 r.p.m.
Mark 12 H.S.	1.95 b.h.p. @ 3,400 r.p.m.
Cooling System	Air cooled, by fan.
Magneto... .. .	Villiers flywheel type.
Carburetter	B.10, or Type V.
Sparking Plug 18 m.m.	Lodge C.B. 3 (unscreened). Lodge S.R. 2 (screened). Lodge B.B.L. For Low Power.
Air filter	Oil wetted or Oil bath type.
Fuel tank capacity	½ gall.
Lubricating oil sump capacity	1 pint.
Recommended tappet clearance	Inlet and exhaust:— Minimum .006". Maximum .010".

* Insist on

GENUINE  SPARES

Running the MARK 10 and 12 ENGINES

INSTALLATION

The engine must be securely fixed in place and be reasonably level, otherwise proper lubrication and the operation of the carburetter, are liable to be adversely affected.

BEFORE STARTING (See also "ROUTINE ATTENTION.")

Fill the sump with the recommended grade of oil up to the underside of the filler hole. This is level with the shoulder of the dipstick fitted to the filler plug.

The bottom end of the dipstick represents the danger level, and the sump must be replenished before the oil reaches this point.

RECOMMENDED GRADES OF OIL

Petrol Engines

Below 16°F. Wakefield Castrolite, (S.A.E.20).

16°F.—90°F. Wakefield Castrol XL (S.A.E.30).

Above 90°F. Wakefield Castrol XXL (S.A.E. 40).

Petrol Vaporising Oil Engines

Below 16°F.—Wakefield Castrol XL (S.A.E. 30).

Above 16°F.—Wakefield Castrol XXL (S.A.E. 40).

Reduction Gear (where fitted)

All temperatures—Wakefield Castrol XL (S.A.E. 30).

(Also see page 6 for further details regarding lubrication).

FUEL

The tank must be filled with good quality fuel.

When the engine has been made to run on either petrol or vaporising oil, the two separate compartments of the fuel tank must be correctly filled with the appropriate fuel. (See page 5).

Note:—Do not mix oil and petrol. The lubrication system of these engines is separate from the fuel supply system.

STARTING

When the engine is cold:—Open the petrol tap.

Close the strangler, which is fitted on the air filter or the carburetter intake.

In cold weather it may be necessary to flood the V type carburetter by depressing the tickler cap projecting above the top of the float chamber.

Wind the rope around the starting pulley in a clockwise direction. One end of the rope is placed in the notch provided in the pulley, the knob at the other end of the rope being held in the hand.

Give a brisk pull to rotate the engine, pulling the rope clear of the starting pulley.

After starting, open the strangler gradually as the engine warms up.
Note:—At extremely low temperatures it is essential that the lighter grade of oil recommended is used. This will enable the engine to rotate quickly enough to start, and also ensure proper circulation of the oil.

It may also be helpful to inject petrol through the sparking plug hole before starting.

When the engine is hot:—The same method is used for starting when the engine is still hot from a recent run, but it is not usually necessary to close the strangler or flood the V type carburetter.

FAILURE TO START

If the engine will not start after a reasonable number of attempts, the cause of the trouble may be found by a systematic check-over as given under the heading "Tracing Troubles," on page 35. Read this section carefully before doing anything to the engine.

STOPPING

The engine can be stopped in three ways.

Closing the fuel tap will shut off the fuel supply, and the engine will stop as soon as the carburetter float chamber is empty.

The ignition system can be switched off by operating the small switch on the back of the armature plate, at the rear of the fan casing. Press the small button at the end of the spring strip, until it touches the contact stud beneath.

On some engines there is also a cut-out switch fitted on top of the fan casing. On pressing this against the sparking plug terminal, the ignition current is earthed.

PETROL-VAPORISING OIL ENGINES

Engines designed to run on either petrol or vaporising oil are fitted with a two-compartment fuel tank.

The smaller of the two compartments contains petrol for starting purposes.

A three-way cock is fitted so that either fuel can be supplied to the engine.

The engine must be started on petrol, and after five minutes running, the three-way cock is switched over to the vaporising oil supply.

A few minutes before stopping the engine, the fuel supply is switched back to petrol, so that there is petrol in the float chamber of the carburetter ready for re-starting.

If this is not done, the vaporising oil must be drained from the carburetter by means of the drain-tap provided before re-starting from cold.

ROUTINE ATTENTION

OIL LEVEL

THE ENGINE MUST BE LEVEL WHEN CHECKING AND TOPPING UP.

After every eight running hours, the level of oil in the engine sump must be checked, and if necessary topped up with the recommended grade of oil.

Do not remove filler plug whilst engine is running.

CHANGING THE OIL

After every 100 hours operation, drain all the old oil from the sump by removing the small slotted plug fitted at the side. When running on vaporising oil, every 75 hours.

This is best done when the engine is warm, as the oil will then run out freely.

Refill the sump with clean new oil of the correct grade.

Note:—If the above operation is not carried out at the proper intervals, the running of the engine may be affected, due to excessive wear and the formation of large deposits of carbon.

AIR FILTER

Regular attention to the air filter is required, especially when the engine is operating under dusty conditions. It is important to see that the filter does not become choked, or the engine will overheat and the fuel consumption become excessive.

If the engine runs better without the filter, then the filter needs cleaning. Directions for this operation are given on page 15.

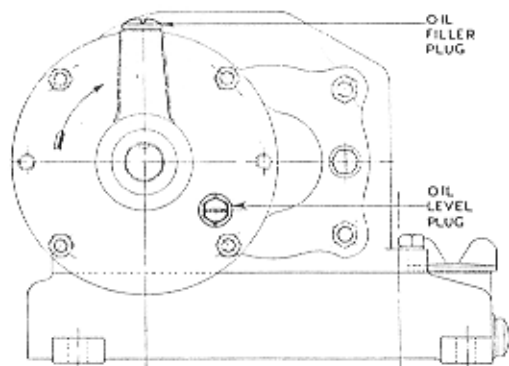

3 : 1
REDUCTION
GEAR Fig. 1

OIL LEVEL IN REDUCTION GEAR

Some engines are fitted with a reduction gear, and this should be kept filled to the oil level plug with Castrol XL oil.

Once a week remove the oil level plug from the reduction gear casing, and if necessary top up with fresh oil to the proper level. Fig. 1 and Fig. 1a show the positions of the oil filler and level plugs for the 3 : 1 and 6 : 1 reduction gear.

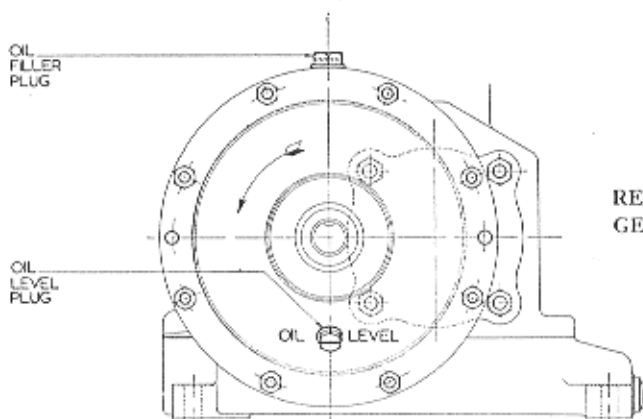

6 : 1
REDUCTION
GEAR Fig. 1a

MAINTENANCE AND REPAIRS

PETROL FILTER

Occasional examination and cleaning of the filter gauze is desirable. This filter is accessible by unscrewing the banjo bolt on the carburetter.

SPARKING PLUG

Clean and re-set the points .020" gap after each 100 hours operation. Adjustment of the gap should be done by moving the points attached to the outer body of the plug. NEVER BEND THE CENTRE PIN. Keep the outside of the plug insulation free from water and dirt. When screwing the plug in the cylinder head, should any undue stiffness be experienced, do not use force but examine the threads for any particles of grit or carbon which may be present. These must be removed, otherwise the threads in the cylinder head may be damaged. It is a good plan to smear a little graphite grease on the plug threads before replacing.

CONTACT BREAKER

The contact breaker points should be checked occasionally to see that they are clean, that the gap when the points are open is between .012" and .015" and that they open and close properly. Access is obtainable after the starter pulley is removed. The screwdriver supplied has a feeler gauge attached which should be used to check the gap. See page 15 for method of adjustment, etc.

DECARBONISING

This will be necessary at intervals, varying according to the type of service the engine has to perform, but generally after every 200/300 hours operation. If the engine "knocks" at normal loads but not when the load is reduced, it is usually an indication that there is an excessive amount of carbon on the piston and the inside of the cylinder head. To remove the head, detach the fan casing and unscrew the six holding down nuts. It is advisable to have a new gasket available for replacement in the event of the original being damaged.

VALVE GRINDING

While the engine is being decarbonised raise the valves and inspect the condition of the seats to see whether they require re-grinding. When the valve springs are compressed, the collars which hold the

bottom spring seat in place can be removed, thus allowing the valves to be taken out of the cylinder. All traces of grinding compound must be removed before re-assembly of the valves. A suitable grade of valve grinding compound is carborundum No. 360 Fine. Should it be necessary to recut the valve seating in the cylinder, the included angle is 89°. Inlet and exhaust valves are marked on the head, and are not interchangeable. Valves with .005" over-size stems are available.

VALVE CLEARANCE

When the valves are closed there must be a clearance between the end of the valve stem and the tappet cap. The clearance should be between .006" and .010". If the clearances are less, file the end of the valve stem with a smooth file until the correct clearance is obtained. The end of the stem must be kept flat and square.

MAGNETO TIMING

The magneto is timed so that the contact breaker points commence to open when the piston is 3/16" before top dead centre.

The cam operating the contact breaker lever is rivetted to the flywheel which is driven by a taper on the crankshaft, and if alteration to magneto timing is necessary, the flywheel must be released, by unscrewing the centre nut with the box spanner provided in the tool kit. This nut has a right-hand thread and is imprisoned in the flywheel and it should be unscrewed until the flywheel is just free to revolve on the crankshaft. With the piston in its correct position, the flywheel should then be moved round until the points are just open, then tighten up the nut firmly and re-check the timing. Always set the contact breaker points to .012"/.015" gap **before** timing the magneto, because any alteration to the point gap alters the ignition timing. The nut must be tightly locked by hitting with a hammer on the end of the tommy bar of the "hammer-tight" box spanner.

The taper must be cleaned and lightly oiled before assembly.

Smear a little oil occasionally on the cam profile and on the felt pad which bears on the cam.

GOVERNOR

This is carefully set before delivery to give the specified engine speed. An adjusting nut is fitted above the spring so that a different speed may be obtained when this is really necessary. **NO ADJUSTMENT** can

be made by altering the position of the lever on the shaft. Hunting at light load may occur due to stiffness in the joints of the carburetter links. These should always be quite free, and adjustment of the pivot pins to ensure this, can be made provided that the locknut is tightened up again. If hunting occurs when the joints are free, the throttle adjusting screw should be screwed in, so that the throttle just does not close, without appreciably increasing the engine speed. Hunting may also be due to a weak carburetter setting.

TO RESET GOVERNOR LEVER after removal

Fit governor lever loose on its shaft, connect up carburetter link at each end, turn shaft as far as possible in a **clockwise** direction then move the lever to the right until the throttle is fully open and tighten clamp bolt securely.

CONNECTING ROD

The Connecting Rod is fitted with detachable big-end bearing shells, keyed to prevent rotation.

When replacing the big-end shells, metal must not be removed from the Bearing Cap or Connecting Rod, and care must be taken to ensure that the Assembly Lugs are correctly mated as shown in Fig. 2.

The small-end Bearing is not bushed, and if excessive wear takes place it will be necessary to fit a new Connecting Rod complete

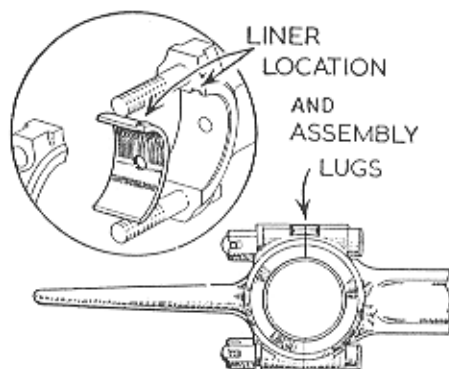

Fig. 2

VALVE TIMING

Correct timing will only be obtained by assembling the camshaft and crankshaft gears so that the timing marks on each gear are together and in line (see Fig. 3).

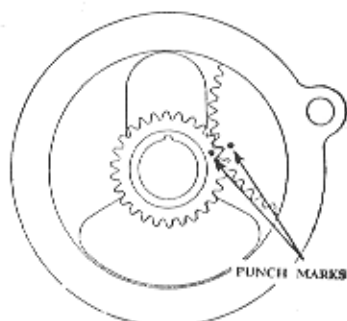

Fig. 3

PISTON RINGS

With new components and Ring fitted squarely in Cylinder, the gap should be between $.008''$ and $.013''$.

Rings should be replaced when the gap exceeds $.030''$.

Oversize Rings are available in two sizes only, i.e. $.015''$ o/s and $.030''$ o/s.

Note:—When fitting Compression Rings the following details must be observed:—

MARK 10.

Top Compression Ring (chromium plated)—fit Ring with lettering "BTM" towards bottom of Piston.

Bottom Compression Ring—fit with "T" uppermost.

MARK 12.

Bottom Compression Ring—fit with letter "T" uppermost.

COOLING SYSTEM

The fan attached to the flywheel need never be removed and it is vital that the complete casing should be in position when the engine is running.

CRANKSHAFT AND CAMSHAFT

Do not remove the crankshaft or camshaft unless it is essential. Care must be taken to ensure that the crankshaft is turned into a suitable position before it is moved. This position is such that the web and the balance weight are clear of the camshaft gear, as shown in Fig. 3.

First remove the connecting rod and the governor gear. Then remove the bearing housing—this is integral with the armature plate, which must be removed, complete with coil etc., before access to the crankshaft is obtained. Care must be taken not to move the crankshaft unless it is in the position described above.

The camshaft can only be moved by pressing its spindle from the outside of the crankcase towards the flywheel side. In re-assembling, note that the two gears engage correctly, indicated by centre punch marks on each gear. The governor gear meshes with the camshaft gear in any position of the teeth.

OIL LEAKS

The outside of the engine should be kept clean. If oil leaks develop, check the tightness of the valve cover plate and the cylinder nuts. Examine oil level—this should not be appreciably higher than the shoulder on the dipstick. The breather valve can be removed and if necessary washed out in paraffin to ensure that the ball can operate freely. If after these precautions, oil still leaks from the crankshaft bearing or governor shaft, it would be advisable to examine the condition of the piston rings. These must be free in their grooves and the rubbing surfaces clean and bright. Remove any carbon from the grooves and replace any damaged rings.

CARBURETTER TYPE V

Adjustment (Standard Type) Fig. 4

If the original setting of the adjustable needle valve has been disturbed proceed as follows:—

Completely close the needle valve by turning clockwise, as far as possible, after the lock nut has been slackened. Do not use force, or the needle valve may be damaged.

Then, open the needle valve between two and two-and-a-half complete turns.

Final adjustment should be made with the engine on full load when the engine is warm by turning the needle valve to the position at which the engine operates most smoothly.

With the setting thus obtained, starting will be satisfactory.

Now test with the engine off load, and adjust the throttle adjusting screw, so that it just bears lightly on the buffer spring. In this condition the engine should run steadily, without "hunting." The locknut on the needle valve should now be tightened.

If when starting from cold, the choke has to be kept closed for several minutes, before the engine runs smoothly, the carburetter setting is too weak, and the needle valve should be opened slightly more.

Adjustment (Pilot Jet Type) Fig. 4a

This Carburetter is different in construction from that illustrated in Fig. 10. The Main Jet situated in the Centre-Piece is not variable in size and the Needle Valve and Lock Nut are not fitted.

The Float cup is held in position by a single Cap Nut, there being a Fibre Joint Washer between the Float Cup and Cap Nut.

Provision is made for adjusting the slow-running mixture and idling speed. The slow-running mixture strength is adjusted by means of the

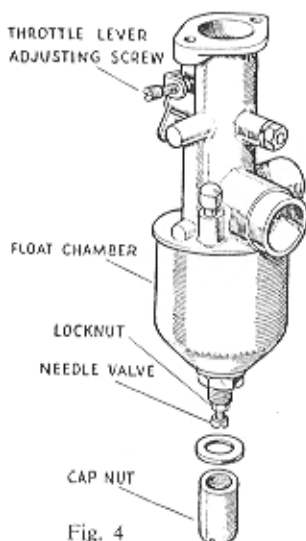

Fig. 4

Pilot Adjuster Screw (B). Screwing the Adjuster in a clockwise direction will enrichen the mixture. For setting the slow-running speed, the Adjusting Screw (A) should be set so that the end bears lightly on the Carburetter Body, thereby preventing complete closure of the Throttle, and ensuring steady running under no load conditions. The Lock Nuts (C) should be securely tightened after the required adjustments have been obtained.

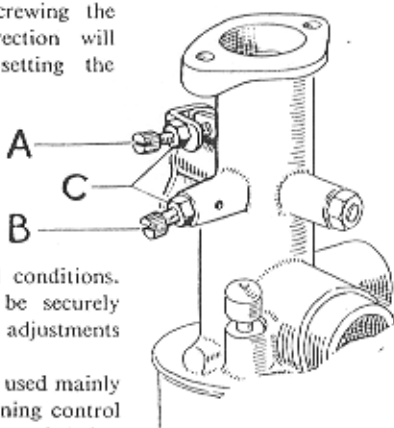

Fig. 4A

The Pilot Jet carburetter is used mainly in conjunction with a slow-running control cable and lever, the engine speed being regulated by altering the tension on the governor spring. The adjuster attached to the slow-running cable is provided to permit the setting of the maximum speed position, and the throttle adjusting screw "A" for the setting of the idling speed. When setting the carburetter for idling speed it is essential that all tension is removed from the governor spring, otherwise a satisfactory tickover will not be obtained.

To Clean Carburetters

In order to carry out this work thoroughly, it is necessary to remove the Carburetter from the Engine.

Standard Type

The Cap Nut covering the Needle Valve should be unscrewed, followed by the Hexagon Nut which will then allow the Float Chamber to be removed. Any accumulated sediment should be cleaned away and the Float examined to make sure it is in good condition. The Float and Float Chamber, Hexagon Nut and Cap Nut can then be replaced making sure that the Fibre Washers are in their correct position.

Pilot Jet Type

Removal of the Cap Nut and Fibre Washer releases the Float Chamber. If it is necessary to remove the Float, the Main Jet will have to be removed from the side of the Centrepiece. After cleaning, reassemble in reverse order.

Notes on type V carburetters.

A filter is fitted over the banjo bolt which secures the end of the petrol pipe to the carburetter body. The bolt should be removed at intervals, and any sediment which accumulates around the filter washed off.

A fuel needle is fitted in the carburetter body, above the float, held in position by a forked brass lever, and any dirt on the needle seating may cause the carburetter to flood, but generally, this can be washed out by permitting petrol to flush through it freely, when the tickler is operated.

If this does not cure the flooding, a light tap on the square end of the needle should produce a satisfactory seating. Take care, however, that the lever is not bent during this process, as this will affect the petrol level. The forked brass lever should have $\frac{1}{16}$ " free movement on its retaining pin, and when the float is pushed up against the lever with the fuel needle in position, the distance between the top of the float and the underside of the carburetter body should be $\frac{3}{32}$ ".

CARBURETTER B.10 (see Fig. 11 page 29)

Flooding of Carburetter

If flooding occurs, the petrol should be turned off and the float chamber (14) removed. The needle jet assembly (8) can then be removed from the top half of the carburetter body (6) and any foreign matter blown out. If flooding still persists, the fuel needle can be lightly tapped on to its seating. When re-assembling the carburetter, take care that the joint washer (27) is correctly fitted and that the fixing screws are securely tightened.

Resetting Pilot and Slow-Running Adjusting Screws

The instructions given below assume that the original pilot jet and slow-running settings have been upset. The main (13) and pilot (29) jets are not adjustable, but must be clear of obstruction and tight in their respective positions.

Screw the pilot adjuster screw (5) lightly on to its seating, then turn approximately two complete turns in an anti-clockwise direction. Turn on the petrol, start the engine, and allow to warm up. With the pilot adjuster screw (5) set in the position given above, the engine should run evenly both on and off load. If the engine 'hunts' when off load, turn the pilot adjuster screw (5) until even running is obtained. The screw should be given only $\frac{1}{4}$ turn at a time and the engine put on load momentarily between checks. If a slow-running control cable or lever is fitted, the throttle stop screw should then be adjusted to give a tick-over of approximately 1,000 r.p.m. with the engine off load and the control in the idling position. If there is any tendency for the engine to fade when a load is suddenly applied, the pilot adjuster screw (5) should be turned in a clockwise direction to slightly richen the mixture.

If the petrol/vaporizing oil carburetter is fitted, the above adjustments must be carried out whilst running on vaporising oil.

Governor

The governor lever should be reset according to the instructions contained on page 10.

Fitting of Replacement Parts

The choke (14), main (13) and pilot jet (29) sizes are selected to give optimum results for each particular application. Either an oil wetted or an oil bath air filter is fitted according to the equipment manufacturer's requirements.

It is most important, therefore, to fit the exact replacements should they eventually become necessary. Main (13) and pilot jets (29) have the calibration figure stamped on the head of the jet (i.e. 40) and the carburetter

body bottom half (14), containing the float chamber and choke tube, has the Part No. cast into the body (i.e. V.1333C). A drain screw, (14a) is fitted to petrol/vaporizing oil carburetter bodies only, and the Part No. of these bodies is suffixed letter P, (i.e. V.1333CP).

AIR FILTERS

The oil bath air filter should be serviced at regular intervals to ensure that the oil is maintained at the correct level and that an excess of sludge does not accumulate in the base of the filter cup. The filter element should be washed out in petrol or paraffin and allowed to drain. It will be re-oiled automatically when the engine is started.

The oil wetted air filter should be removed from the carburetter, washed in petrol or paraffin and re-oiled with engine oil. Allow to drain before re-fitting to the engine.

The frequency at which cleaning of the filter is required will depend upon the conditions under which the engine is running. The oil wetted air filter should be re-oiled before use if the engine has been standing for some time. If the engine runs rich, the filter probably requires cleaning.

CONTACT BREAKER ASSEMBLY

The contact breaker assembly illustrated in Fig. 5, is accessible after the starter pulley has been removed. The assembly is secured to the armature plate by studs and nuts, the studs also serving to hold the condenser in position in the underside of the condenser box.

Adjustment of the contact breaker points is carried out as follows:—

Turn the flywheel clockwise until the rocker arm pad "E" is on the top of the profile of the cam attached to the flywheel boss. Release the screw "A," and position bracket "B" by turning the adjuster cam "C" until the gap between the contact points is between .012" and .015". Tighten screw "A" and withdraw the feeler gauge. It is not necessary to disturb nut "D" when adjusting the contact breaker point gap.

A felt pad "F" is used to keep the cam in a slightly oiled condition and should be periodically soaked in molten high melting point grease. Where it is inconvenient to remove the condenser box assembly for this to be done, a small amount of the heaviest oil available should be put on to the pad. Avoid over-oiling as any excess oil may creep along the rocker arm and cause ignition trouble by fouling the contact breaker points.

The rocker arm pivot pin fits into a graphited bronze bush which requires occasional lubrication with very light oil. Any excessive wear in this bush will cause faulty ignition by allowing the contact breaker gap to vary considerably from the original setting when the engine is running.

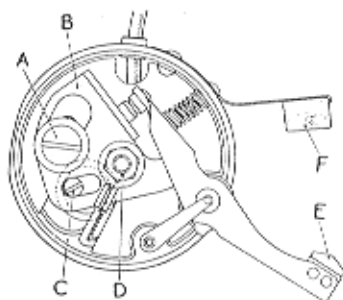

Fig. 5.

SPARE PARTS LISTS

Note:—When ordering spares it is important that the **ENGINE NUMBER** is quoted. Always quote the part number and description, **not** the illustration number.



ENGINE, COWL, and TANK ASSEMBLY. See Fig. 6

ILLUS. NO.	PART NO.	DESCRIPTION	QTY.
1	E.7601	Cap, petrol tank	1
2	EM.1870	Washer, tank cap	1
3	E.781	Screw, trunnion	4
4	EM.276	Trunnion, plain	4
4a	EG.532	Trunnion, tapped	4
5	EM.542	Strap, fuel tank	2
6	EM.596	Strip, ignition cut-out	1
7	EM.1812	Screw, tank bracket	2
8	DM.543	Bracket, fuel tank	1
9	DM.544	Bracket, fuel tank	1
10	EM.539	Screw, tank bracket	2
—	EM.569	Strip, cowl stiffening	1
11	EM.531	Bolt, starter pulley	1
12	E.424	Washer, spring	1
13	CM.509	Pulley, starter	1
14	AM.519	Cowl	1
15	R.56/A.55	Flywheel, magneto	1
16	DM.530	Washer, joint, armature plate	1
17	EM.5257	Washer	2
18	E.6849	Screw, cowl fixing	2
19	V.107x4E	Washer, tap	1
20	E.9724	Tap, fuel with filter gauze	1
21	CM.970	Tank, petrol, $\frac{1}{2}$ gallon, with cap	1
22	DM.503	Piston, standard, Mark 10	1
—	DM.656	Piston, .015" O/S, Mark 10	1
—	DM.659	Piston, .030" O/S, Mark 10	1
—	DM.927	Piston, standard, Mark 12	1
—	DM.1272	Piston, .015" O/S, Mark 12	1
—	DM.1273	Piston, .030" O/S, Mark 12	1
23	EM.518	Ring, piston, oil control, standard, Mark 10	1
—	EM.658	Ring, piston, oil control, .015" O/S, Mark 10	1

ENGINE, COWL, and TANK ASSEMBLY—continued.

ILLUS. NO.	PART NO.	DESCRIPTION	QTY.
—	EM.661	Ring, piston, oil control, .030° O/S, Mark 10 ...	1
—	EM.943	Ring, piston, oil control, standard, Mark 12 ...	1
—	EM.1098	Ring, piston, oil control, .015° O/S, Mark 12 ...	1
—	EM.1101	Ring, piston, oil control, .030° O/S, Mark 12 ...	1
24	EM.1771	Ring, piston, top compression, standard, Mark 10	1
—	EM.1777	Ring, piston, top compression, .015° O/S, Mark 10	1
—	EM.1778	Ring, piston, top compression, .030° O/S, Mark 10	1
—	EM.941	Ring, piston, top compression, standard, Mark 12	1
—	EM.1096	Ring, piston, top compression, .015° O/S, Mark 12	1
—	EM.1059	Ring, piston, top compression, .030° O/S, Mark 12	1
25	EM.839	Ring, piston, middle, standard, Mark 10 ...	1
—	EM.916	Ring, piston, middle, .015° O/S, Mark 10 ...	1
—	EM.917	Ring, piston, middle, .030° O/S, Mark 10 ...	1
—	EM.942	Ring, piston, middle, standard, Mark 12 ...	1
—	EM.1097	Ring, piston, middle, .015° O/S, Mark 12 ...	1
—	EM.1100	Ring, piston, middle, .030° O/S, Mark 12 ...	1
26	EM.132	Circlip, gudgeon pin ...	2
27	EM.522	Pin, gudgeon, Mark 10 ...	1
—	EM.926	Pin, gudgeon, Mark 12 ...	1
28	DM.613	Rod, connecting, assembly with liners, Mark 10...	1
—	DM.553	Rod, connecting, assembly less liners, Mark 10 ...	1
—	DM.1041	Rod, connecting, assembly with liners, Mark 12...	1
—	DM.911	Rod, connecting, assembly, less liners, Mark 12 ...	1
29	EM.535	Bolt, connecting rod, Mark 10 ...	2
—	EM.131	Bolt, connecting rod, Mark 12 ...	2
30	EM.554	Liner, connecting rod, Mark 10 ...	2
—	EM.913	Liner, connecting rod, Mark 12 ...	2
31	E.2924	Washer, plain ...	2
32	EM.283	Pin, split ...	2
33	DM.815	Trough, oil ...	1
34	Quote Engine No.	Base, crankcase ...	1
35	E.364	Nut ...	6
36	E.9723	Washer, shakeproof ...	4
37	E.363	Stud, crankcase base ...	4
38	Z.1010x6	Stud, crankcase/oil trough ...	2
39	E.2924	Washer, plain ...	4
40	E.1430	Washer, spring ...	6
41	E.401	Nut, oil trough and governor lever bolt ...	3
42	EM.212/1	Plug, oil filler ...	1
43	FG.156	Washer, oil filler plug ...	1
44	E.4104/1	Plug, drain, crankcase base ...	1
45	V.107x3E	Washer, drain plug ...	1

ENGINE, COWL, and TANK ASSEMBLY—continued.

ILLUS. NO.	PART NO.	DESCRIPTION	QTY.
46	LS.8	Bearing, ball, $\frac{3}{4}$ " x $1\frac{1}{8}$ " x $\frac{3}{16}$ "	2
47	EM.523/2	Gear, timing	1
48	Quote Engine No.	Crankshaft, Mark 10	1
—	Quote Engine No.	Crankshaft, Mark 12	1
49	E.4873	Key, timing gear wheel	1
50	EM.664	Circlip, ball bearing	1
51	EM.257	Stud, armature plate fixing	4
52	E.1962	Screw, tank bracket	2
53	EM.1799	Stud, cylinder head	6
54	EM.512	Valve, inlet, standard stem, Mark 10	1
—	EM.1009	Valve, inlet, .005" O/S, stem, Mark 10	1
—	EM.925	Valve, inlet, standard stem, Mark 12	1
—	EM.1362	Valve, inlet, .005" O/S, stem, Mark 12	1
55	EM.567	Valve, exhaust, standard stem, Mark 10	1
—	EM.1010	Valve, exhaust, .005" O/S, stem, Mark 10	1
—	EM.929	Valve, exhaust, standard stem, Mark 12	1
—	EM.1363	Valve, exhaust, .005" O/S, stem, Mark 12	1
56	EM.1798	Nut, pillar, cylinder head studs	4
57	FG.186E	Washer, cylinder head nuts	6
58	BM.505	Head, cylinder	1
59	DM.516	Washer, joint, cylinder head	1
60	EM.202	Washer, joint, exhaust and inlet pipe	2
61	EM.327	Silencer, exhaust, complete	1
62	E.2539	Nut, small hexagon	6
*63	FG.185E	Stud, inlet and exhaust pipe	4
64	H.104x8	Washer, breather valve	1
65	EM.207	Valve, breather assembly	1
*66	DM.540	Pipe, inlet	1
*67	EM.216	Washer, joint, inlet pipe/carburetter	1
*68	W.185E	Bolt, carburetter/inlet pipe	2
69	EM.513/1	Spring, valve	2
70	EM.514	Seat, valve spring	2
71	EM.515	Collar, valve	2
72	EM.597	Plate, valve cover	1
73	EM.218	Screw, valve cover plate	1
74	V.476E	Washer, plate screw	1
75	EM.533	Washer, joint	1
76	EM.223	Bolt, governor adjuster anchor	1
77	EM.236	Nut, locking anchor bolt	1
78	E.4869	Adjuster, governor spring	1
79	1002x15E	Nut, adjuster, locking	1
80	EM.547	Spring, governor, (over 2,400 r.p.m.)	1

ENGINE, COWL, and TANK ASSEMBLY—continued.

ILLUS. NO.	PART NO.	DESCRIPTION	QTY.
—	EM.222	Spring, governor, (1,500 to 2,400 r.p.m.) ...	1
—	EM.921	Spring, governor, (up to 1,500 r.p.m.) ...	1
*81	V.626E	Pin, governor link pivot ...	1
82	1004x5E	Nut, pin locking ...	2
83	EM.194	Link, governor lever to carburetter ...	1
*84	DM.169	Lever, governor ...	1
*85	E.783	Bolt, governor lever clamp ...	1
*86	EM.136	Crank, governor ...	1
*87	V.301E	Pin, split ...	1
*88	EM.137	Bush, governor crank ...	1
89	EM.520	Tappet ...	1
90	DM.507	Camshaft and gear ...	1
91	EM.521	Spindle, camshaft ...	1
92	EM.546	Circlip ...	1
—	DM.286	Gear, governor, assembly ...	1
93	CM.176/3	Gear, governor ...	1
94	EM.217	Pin, fulcrum ...	2
95	EM.701	Weight, governor ...	2
96	EM.128/1	Spindle, governor gear ...	1
97	EM.129/1	Sleeve, governor spindle ...	1
98	V.111x2E	Pin, split ...	6
99	EM.341	Plate, governor spindle locking ...	1
100	V.1181E	Pipe, fuel ...	1
101	DM.529	Washer, joint, crankcase base ...	1
102	EM.545	Washer, ball bearing packing ...	As required
103	E.9718	Seal, oil, in crankcase ...	1
104	AM.501/3	Cylinder and crankcase, Mark 10 ...	1
—	DM.577/3	Cylinder and crankcase, spigotted, Mark 10 ...	1
—	AM.928	Cylinder and crankcase, Mark 12 ...	1
—	DM.1040	Cylinder and crankcase, spigotted, Mark 12 ...	1

*See page 28 for alternative parts when B.10 carburetter is fitted.

Fig. 6 illustrates the engine with fuel tank fitted on the side, but when tank is fitted to top of engine the following are substituted:—

—	CM.873	Cowl ...	1
—	DM.866	Bracket, tank ...	1
—	DM.867	Bracket, tank ...	1
—	DG.513	Strap, tank ...	2
3	E.781	Screw, tank strap ...	2
4	EM.276	Trunnion, plain ...	2
5	EG.532	Trunnion, tapped ...	2
—	EM.1812	Screw, bracket ...	4

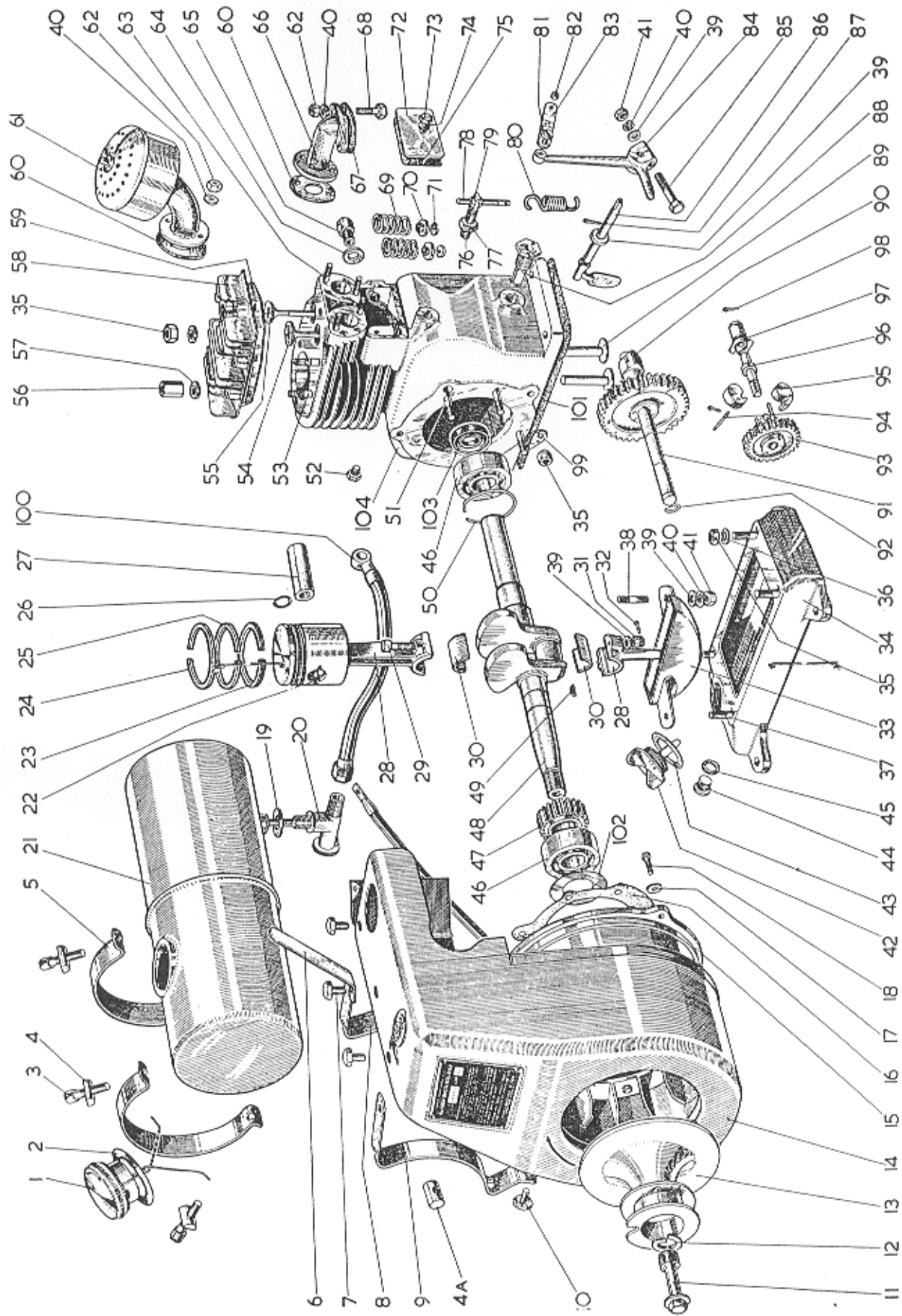

ENGINE, COWL AND TANK Fig. 6.

Fig. 7 REDUCTION GEAR (Ratio 3-1)

ILLUS NO.	PART NO.	DESCRIPTION	QTY.
—	DM.577/3	Cylinder & Crankcase with Studs. Mark 10 R.G. Engine	1
—	DM. 1040	As above, for Mark 12 R.G. Engine	1
—	E.2152	Stud, long, in Crankcase for Reduction Gear Casing	2
—	E.8470	Stud, short, in Crankcase for Reduction Gear Casing	2
1	E.5267	Oil Filler Plug	1
2	V.107 × 3E	Washer	1
3	EM.1813	Woodruff Key for large Gear Wheel	1
4	DM.773	Large Gear Wheel	1
5	LS.7	Inner Ball Bearing $\frac{1}{2}'' \times 1\frac{1}{16}'' \times \frac{1}{16}''$	1
6 & 8	E.364	Nut for Gear-case Retaining Stud (large hexagon)	2
7 & 10	E.1050	Spring Washer	2
9	FG.185	Stud in Gearcase securing End Cover	4
11	E.1962	Plug	1
12	E.1905	Washer	1
13	CM.770	Gear Casing	1
14	DM.814	Gasket	1
15	EM.775	Crankshaft Pinion	1
16	EM.949	Circlip	1
17	EM.793	Key	1
—	DM.774	Crankshaft, Mark 10 R.G. Engine	1
—	CM.1052	Crankshaft, Mark 12 R.G. Engine	1
18	E.9718	Oil Seal	1
19	E.401	Nut	4
20	E.1430	Spring Washer	4
21	E.1962	Oil Level Plug and extractor hole plug	2
22	E.1905	Washer for above	2
23	CM.771	End Cover	1
24	LS.8	Outer Ball Bearing $\frac{1}{2}'' \times 1\frac{1}{8}'' \times \frac{3}{16}''$	1
25	DM.772	Gear Shaft	1
26	E.3961	Nut for Gearcase Retaining Stud (small hexagon)	2
27	E.1050	Spring Washer	2
28	DM.833	Gasket	1

Fig. 8 REDUCTION GEAR (Ratio 6-1)

—	DM.577/3	As 3—1 Ratio	1
—	DM.1040	As 3—1 Ratio	1
1	E.1905	Washer, Oil Level Plug	1
2	E.1962	Oil Level Plug	1
3	E.401	Nut, $\frac{1}{4}''$	8
4	E.1430	Spring Washer, $\frac{1}{2}''$	8
5	FG.185	Stud in Gearcase	8
6	V.107 × 3E	Washer, Oil Filler Plug	1
7	E.5267	Oil Filler Plug	1
8	CM.1337	End Cover	1
9	DM.1343	End Cover Gasket	1
10	E.9718	Oil Seal	1
11	EM.1813	Key for Large Wheel	1
12	MS.10	Outer Ball Bearing $1'' \times 2\frac{1}{8}'' \times \frac{3}{4}''$	1
13	DM.1341	Gearshaft	1
14	DM.1338	Large Wheel	1
15	LS.8	Inner Ball Bearing $\frac{3}{4}'' \times 1\frac{1}{8}'' \times \frac{3}{16}''$	1
16	CM.1336	Gear Casing	1
17	DM.814	Gasket	1
18	E.364	Nut, $\frac{3}{16}''$	4
19	E.1050	Spring Washer	4
20	E.2152	Stud	4
21	DM.1339	Crankshaft, Mark 10 R.G. Engine	1
21	DM.1340	Crankshaft, Mark 12 R.G. Engine	1
22	EM.1342	Crankshaft Pinion	1
23	EM.1344	Circlip	1

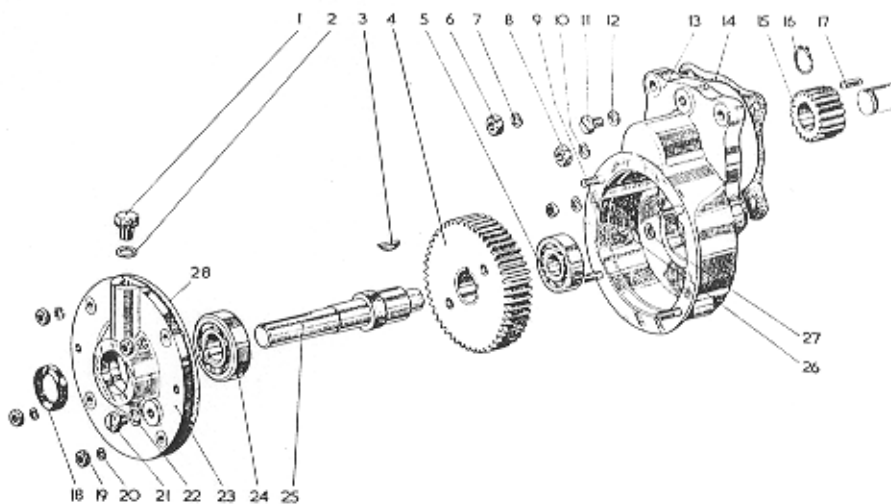

REDUCTION GEAR (Ratio 3-1) Fig. 7

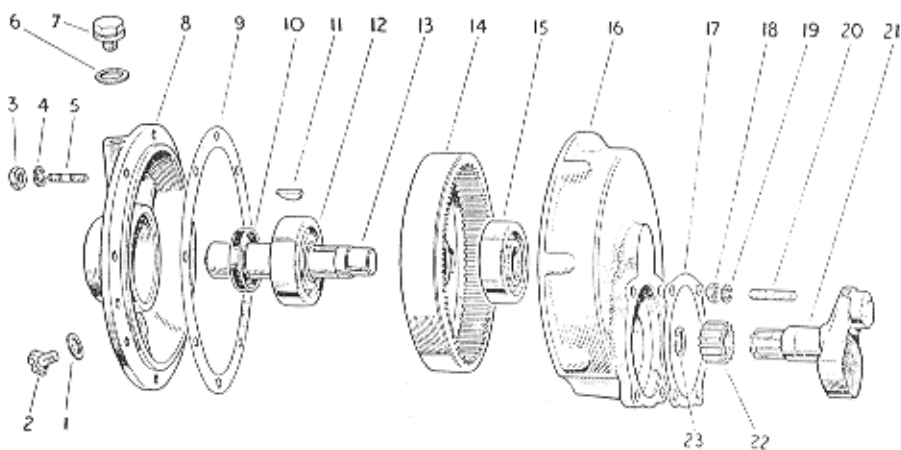

REDUCTION GEAR (Ratio 6-1) Fig. 8

MAGNETO Fig. 9

ILLUS. NO.	PART NO.	DESCRIPTION	QTY.
1	1002x15E	Nut, fan fixing	4
2	M.2707E	Washer, shakeproof Rotor R.56 only	5
3	M.1797E	Screw, pole piece and fan	4
4	M.1670E	Screw, cut-out terminal	1
5	1113x5E	Washer	2
6	M.2924E	Lead, L.T., coil to cut-out screw	1
7	1013x13E	Bush, screw insulating	1
8	M.1634E	Coil, ignition	1
9	EM.220	Screw, armature plate fixing	1
10	—	Lead, H.T. complete	1
11	1124x8E	Terminal, H.T.	1
12	E.869	Washer, felt	1
13	M.2703E	Screw, spring fixing	1
14	1010x11E	Spring	1
15	1046x13E	Pad, H.T. pick-up	1
16	M.1805E	Washer, insulating	1
17	1113x5E	Washer	1
18	EM.1001	Nut	1
19	1086x4E	Switch, cut-out	1
20	1089x9E	Screw, cut-out switch	1
21	M.1514E	Cheek, right-hand, ignition coil	1
22	M.1799E	Screw, coil cheek fixing	4
23	M.2162E	Screw, coil locking	2
24	E.9718	Seal, oil	1
25	M.1742E	Nut, cap	1
26	A.55	Armature plate assembly (standard type)	1
or	A.58	Armature plate assembly (screened type)	1
27	1053x1E	Stud, condenser box fixing	2
28	M.1750E	Condenser	1
29	M.2505E	Box, only, less condenser and contact breaker	1
—	M.2506E	Box, with condenser only	1
—	M.2741E	Box, complete, (items 27-44 inclusive)	1
30	M.2720E	Bush, lead insulating	1
31	M.2310E	Bush, cam insulating	1
32	M.1291E	Terminal	1
33	M.2309E	Plate, insulating	1
34	M.2313E	Bracket, contact point	1
35	M.1805E	Washer, insulating	1
36	M.1802E	Washer	1
37	1113x5E	Washer	1
38	M.1801E	Screw, bracket locking	1
39	1113x4E	Nut	1
40	482	Lead, condenser box/coil	1
41	M.1714E	Rocker arm with point and pad	1
42	1047x3E	Spring, rocker arm	1
43	1010x16E	Bush, lead insulating	1
44	M.2311E	Cam, point bracket adjusting	1
45	E.401	Nut, armature plate fixing	1

See page 34 for illustration numbers 46 to 52

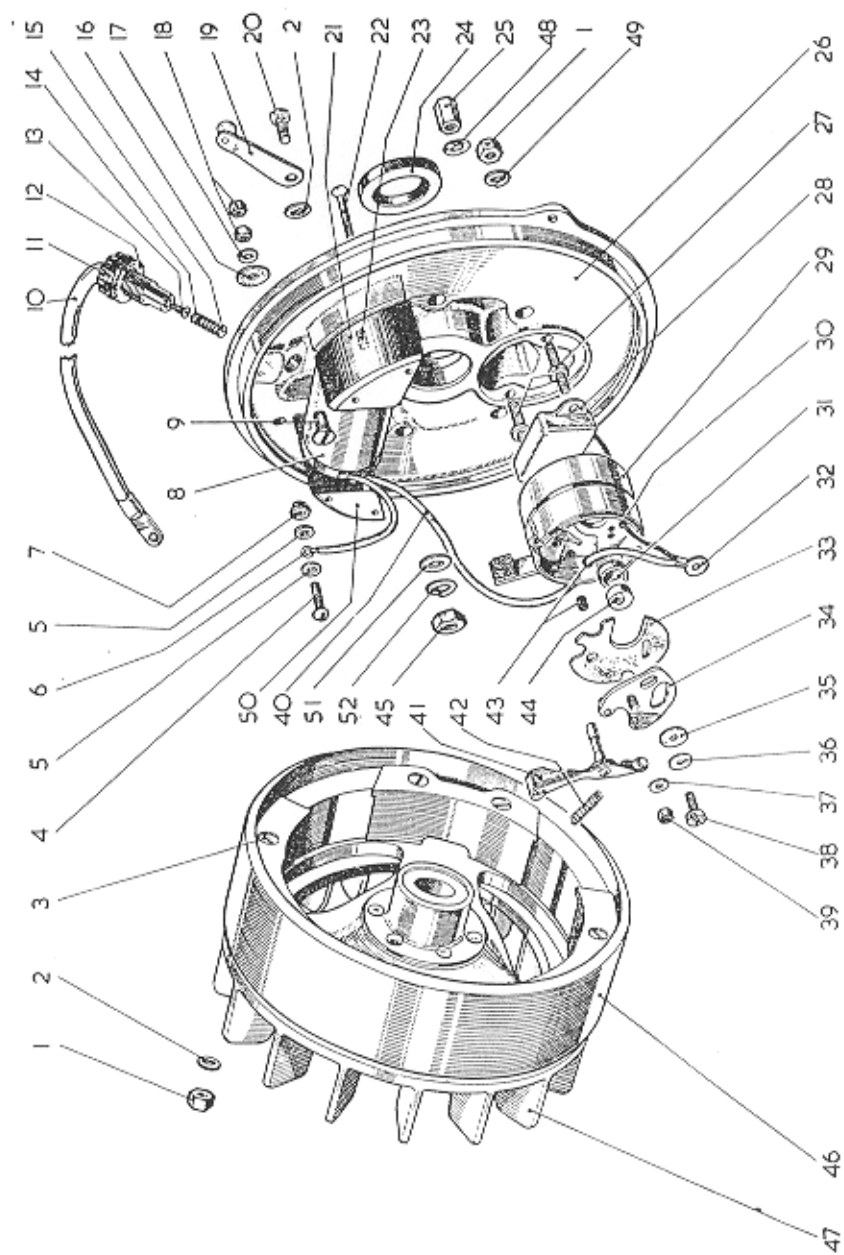

MAGNETO Fig. 9

CARBURETTER (Type V.) Fig. 10

ILL. U.S. NO.	PART NO.	DESCRIPTION	QTY
	Quote Engine No.	Carburetter complete	1
1	EM.776	Choke tube (Speeds under 1,500 r.p.m.) ...	1
	or EM.378	Choke tube (1,500—3,000 r.p.m.) ...	1
	or EM.1421/1	Choke tube (3,000—3,400 r.p.m.) ...	1
2	EM.366	Compensating Tube ...	1
3	EM.379	Centrepiece with Jet M.450 (Not supplied separately) and Compensating Tube M.366 ...	1
4	1113×4E	Locknut for Jet Needle ...	1
5	EM.451	Jet Needle Valve ...	1
6	V.107×3E	Centrepiece Washer ...	1
7	CM.380	Mixing Chamber Body ...	1
8	V.223E & V.207E	Tickler Cap and Spindle ...	1
9	V.369E	Tickler Spring ...	1
—	V.596E	Tickler complete with Spring and Split Pin (See Item 16) ...	1
10	E.7529	Spring Washer ...	2
11	1004×5E	Throttle Spindle Nut ...	1
12	1002×15E	Nut for Air Filter Clip ...	1
13	EM.487	Air Filter complete with Clip, Nut and Bolt ...	1
14	EM.612	Clip for Air Filter ...	1
15	E.5102	Screw for Clip ...	1
16	V.111×2E	Split Pin for Tickler ...	1
17	V.107×1E	Carburetter Float ...	1
18	V.107×4E	Washer for Float Cup Retaining Nut ...	1
19	V.383E	Washer for Cap Nut ...	1
20	EM. 362	Screw for Throttle Plate ...	1
21	V.1305E	Spring Washer $\frac{1}{4}$ " ...	1
22	1113×5E	Plain Washer ...	1
23	EM.360	Throttle Plate ...	1
24	EM.619	Throttle Stop Screw ...	1
25	V.136×6E	Spring for Screw ...	1
26	EM. 367	Throttle Lever and Spindle EM.455 ...	1
27	V.1304E	Screw for Choke Tube $\frac{1}{4}$ "×4 B.A. ...	1
28	EM. 366	Compensating Tube ...	1
29	V.383E	Washer (small hole) for Banjo Bolt ...	1
30	V.404E	Gauze Filter for Banjo Bolt ...	1
31	H.104×8	Washer (large hole) for Banjo Bolt ...	1
32	V.382E	Banjo Bolt ...	1
33	V.355E	Fuel Needle ...	1
34	V.257E	Fuel Needle Lever ...	1
35	V.107×2E	Washer for Float Cup ...	1
36	V.375E	Pin for Fuel Needle Lever ...	1
37	V.146×6E	Float Cup ...	1
38	EM.453	Float Cup Retaining Nut ...	1
39	EM.454	Cap Nut ...	1
—	EM.216	Gasket, Carburetter to Elbow Pipe ...	1
—	W.185	Clamp Bolt, Carburetter to Elbow Pipe ...	2
—	E.2539	Nut for Clamp Bolt ...	2
—	E.1430	Spring Washer ...	2
—	EM.295	Throttle Stop Spring ...	1
—	V.424E	Throttle Stop Spring Screw ...	1

See also pages 30 and 31 for Vaporising Oil and Pilot Jet Carburetters.

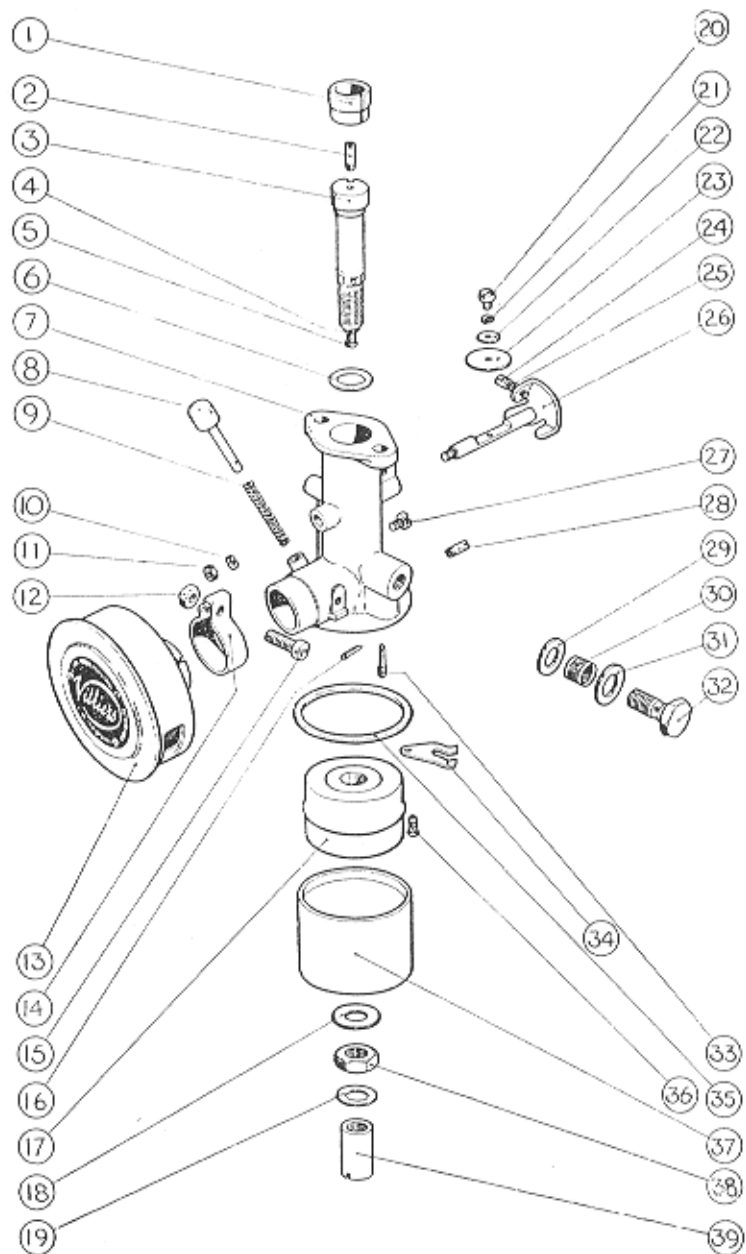

CARBURETTER (Type V) Fig. 10

CARBURETTER TYPE B.10 Fig. 11

ILLUS. NO.	PART NO.	DESCRIPTION	QTY.
—	Quote Engine No.	Carburetter complete. Oil-wetted air filter (less inlet pipe and governor lever) ...	1
or	Quote Engine No.	Carburetter complete. Oil bath air filter (less inlet pipe and governor lever) ...	1
1	DM.1882	Pipe, inlet ...	1
2	EM.1919	Washer, joint, carburetter/inlet pipe ...	1
3	E.5102	Screw, carburetter, top/bottom fixing ...	2
4	E.4270	Spring, pilot jet adjusting screw ...	1
5	V.885E	Screw, pilot jet adjusting ...	1
6	V.1303C	Body, top half ...	1
7	V.157x2E	Washer, carburetter/inlet pipe fixing bolt ...	2
8	V.1459E	Needle, fuel control, assembly ...	1
9	V.383E	Washer, banjo ...	1
10	V.404E	Gauze, banjo screw ...	1
11	H.104x8E	Washer, banjo ...	1
12	V.382E	Bolt, banjo ...	1
13	V.1323E	Jet, main 36 c.c. ...	1
or	V.1543E	Jet, main 38 c.c. ...	1
or	V.1545E	Jet, main 40 c.c. ...	1
or	V.1544E	Jet, main 42 c.c. ...	1
or	V.1546E	Jet, main 44 c.c. ...	1
or	V.1704E	Jet, main, 46 c.c. ...	1
or	Quote Engine No.	Jet, main (for calibrations other than above) ...	1
14	V.1333C	Body, bottom half, $\frac{3}{8}$ " choke ...	1
or	V.1333CP	Body, bottom half, $\frac{3}{8}$ " choke, for V.O. ...	1
or	V.1334C	Body, bottom half, $\frac{5}{16}$ " choke ...	1
or	V.1331CP	Body, bottom half, $\frac{5}{16}$ " choke, for V.O. ...	1
or	V.1335C	Body, bottom half, $\frac{1}{2}$ " choke ...	1
or	V.1335CP	Body, bottom half, $\frac{1}{2}$ " choke, for V.O. ...	1
14a	V.1467E	Screw, float chamber drain (for V.O. body) ...	1
15	V.111x2E	Pin, split ...	1
16	V.1246E	Plate, strangler ...	1
17	I022x4E	Screw, cover fixing ...	2
18	V.1363E/V.1245E	Lever and spindle strangler ...	1
19	EM.1159	Bolt, carburetter/inlet pipe ...	2
20	V.1241E	Screw, throttle plate ...	1
21	V.1573E	Washer, throttle plate ...	1
22	V.1240E	Plate, throttle ...	1
23	V.1238E/V.1239E	Lever and spindle, throttle ...	1
24	E.2539	Nut, carburetter/inlet pipe bolt ...	2
25	V.1332E	Spring, throttle stop screw ...	1
26	V.1331E	Screw, throttle stop ...	1
27	V.1353E	Washer, joint, carburetter top/bottom ...	1
28	V.1031E	Float ...	1
29	V.1527E/V.1324E	Jet, pilot, with tube, 35 c.c. ...	1
30	V.1018E	Plunger, strangler, spindle locating ...	1
31	EM.1166/1	Spring, strangler spindle plunger ...	1
32	V.1302E	Screw, strangler spring and cover locating ...	1

OIL BATH AIR FILTERS

33	V.1270C	Cover, filter ...	1
34	V.1314D	Filter element ...	1
35	V.1272D	Cup ...	1
36	V.1351E	Clip, cup ...	1
37	V.1313E	Turnbuckle ...	1
38	V.1352E	Screw, turnbuckle ...	1

See page 34 for illustration numbers 39 to 54.

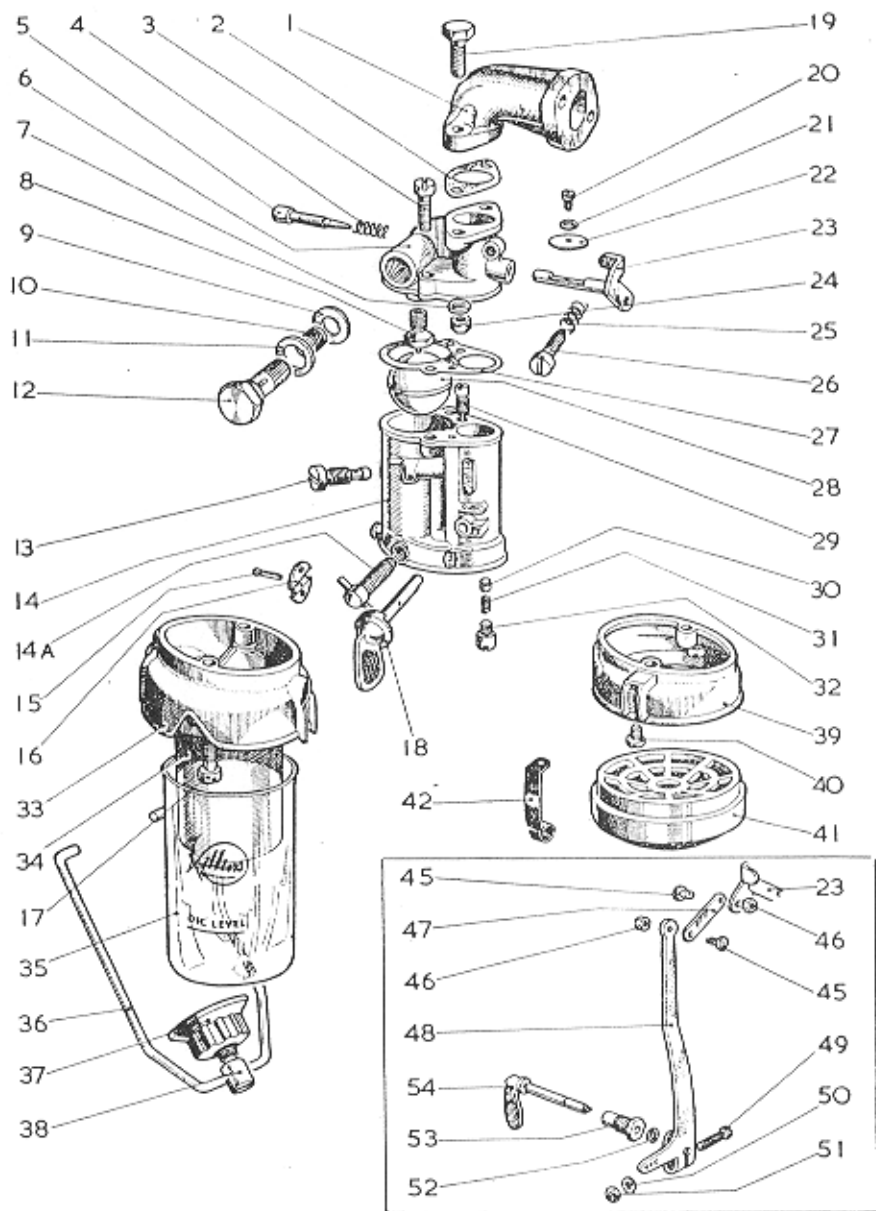

CARBURETTER TYPE B.10 Fig. 11

CARBURETTER TYPE B.10/L.

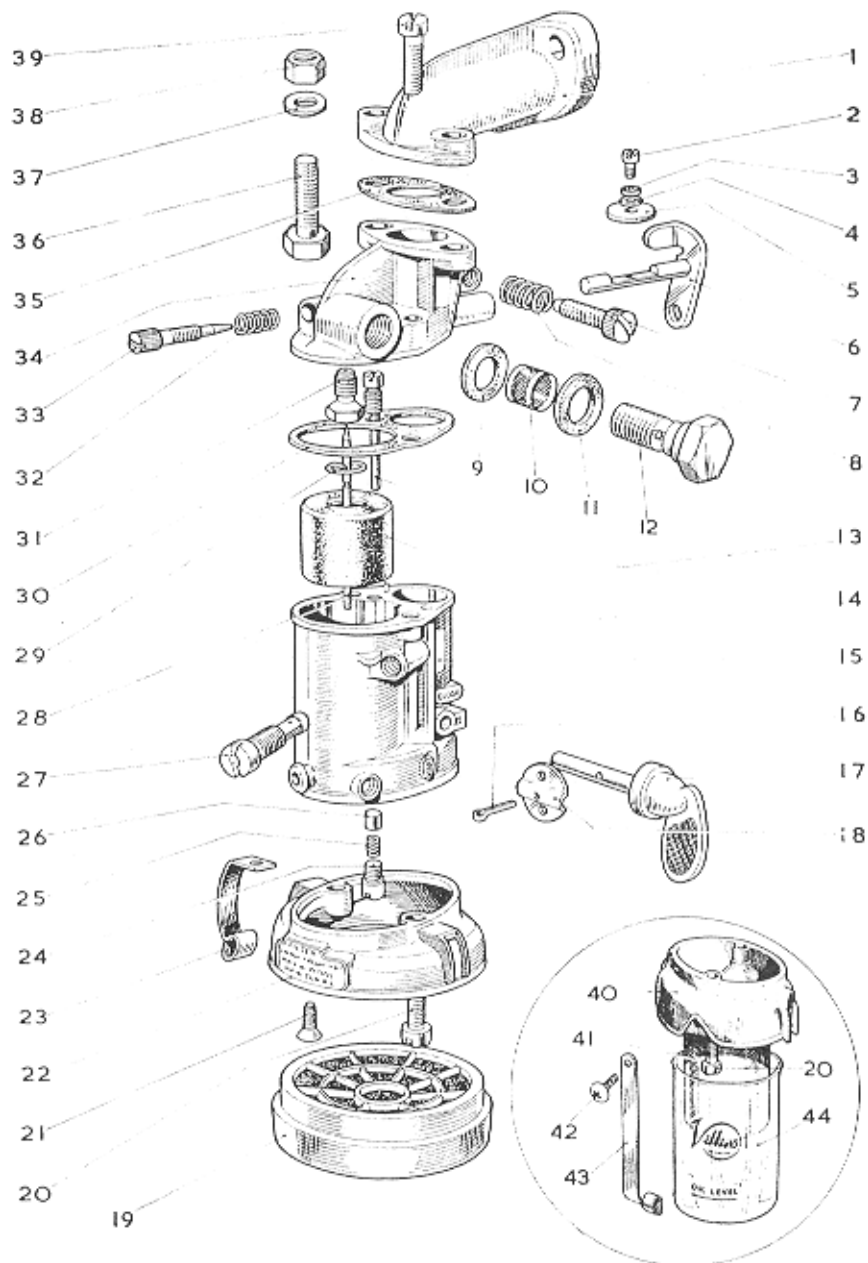

CARBURETTER, TYPE B.10/1.

ILLUS No.	PART No.	DESCRIPTION	
1	DM.1882	Pipe, inlet.	
2	V.1241E	Screw, throttle plate.	
3	—	Not now fitted.	
4	1035 × 7E	Washer, plain, throttle plate.	
5	V.1240E	Plate, throttle.	
6	25659/60	Lever and spindle, throttle.	
7	V.1331E	Screw, throttle stop.	
8	V.1332E	Spring, throttle stop screw.	
9	V.383E	Washer, banjo, small hole.	
10	V.404E	Gauze, banjo bolt.	
11	H.104 × 8E	Washer, banjo, large hole.	
12	V.382E	Bolt, banjo.	
13	V.1527E/V.1324E	Jet, pilot with tube, 35 c.c.	
14	V.2100E	Float.	
15	V.2075C	Body, bottom, $\frac{5}{16}$ " choke	} For vaporising oil engines affix letters C/P.
or	V.2076C	" " $\frac{3}{8}$ " "	
or	V.2077C	" " $\frac{7}{16}$ " "	
or	V.2078C	" " $\frac{1}{2}$ " "	
16	V.1980E	Pin, split.	
17	V.1363E/V.1245E	Lever and spindle, strangler.	
18	V.1246E	Plate, strangler.	
19	V.1383D	Filter, oil wetted.	
20	1022 × 4E	Screw, oil wetted filter cover (2).	
21	V.829/1E	Screw, clip (2).	
22	V.1344/1D	Cover, oil wetted filter.	
23	V.1349D	Clip, oil wetted filter cover (2).	
24	V.1302E	Screw, strangler spring and cover locating.	
25	EM.1166/1	Spring, plunger.	
26	V.1018E	Plunger, locating strangler spindle.	
27	V.1803E	Jet, main, 34 c.c.	
or	V.1323E	" " 36 c.c.	
or	V.1543E	" " 38 c.c.	

CARBURETTER, TYPE B.10/1—continued.

ILLUS No.	PART No.	DESCRIPTION
or	V.1545E	Jet, main, 40 c.c.
or	V.1544E 42 c.c.
or	V.1546E 44 c.c.
or	V.1704E 46 c.c.
or	V.1594E 48 c.c.
28	V.1873E	Needle, fuel.
29	26697	Circlip, fuel needle.
30	V.1353E	Washer, joint, body.
31	V.1871E	Seating, fuel needle valve.
32	E.4270	Spring, pilot jet adjuster screw.
33	V.885E	Screw, pilot jet adjusting.
34	V.1303C	Body, top half.
35	EM.1919	Washer, joint, carburetter/inlet pipe.
or	26593	Washer, joint, carburetter flange
—	E.10104/1	Washer, insulating
36	EM.1580	Bolt, carburetter/inlet pipe (2).
37	V.157 × 2E	Washer, carburetter/inlet pipe bolt (2).
38	EM.1565	Nut, carburetter/inlet pipe bolts (2)
39	E.5102	Screw, body, top/bottom (2).
40	V.1270/1C	Cover, filter, oil bath.
41	V.1314D	Filter element, oil bath.
42	EM.2298	Screw, clip, oil bath filter (2)
43	V.1729E	Clip, cup, oil bath filter (2).
44	V.1272D	Cup, oil bath filter.
	V.1467E	Screw, float chamber drain (for Vap. Oil body).
	V.1273E	Pipe, petrol, 11" Quote engine number
or	V.1254E 12" for other lengths.

The earlier B.10 carburetter differs from the above in the following respects :—

	V.1459E	Needle, fuel control assembly (in lieu of illus. 31).
	V.1031E	Float (in lieu of illus. 14).
	V.1333C	Body, bottom half, ½" choke (in lieu of illus. 15).
or	V.1334C ¾" .. (..).
or	V.1335C 1" .. (..).

SPECIAL PARTS FOR PILOT JET TYPE V CARBURETTER.

See Fig. 12 for illustration reference.

ITEM NO.	PART NO.	DESCRIPTION	QTY.
6	V.566E	Adjuster Screw, Pilot Jet	1
7	EM.339	Locknut, pilot jet screw	1
8	CM.358	Carburetter Body	1
9	EM.790	Pilot Jet	1
10	EM.379/EM.800	Centre-piece and Jet	1
11	V.105 × 10E	Pilot Jet Tube	1
12	EM.1257	Limit Jet—30 c.c.—Mk. 10 Engine	1
12	EM.1597	Limit Jet—50 c.c.—Mk. 12 Engine	1
13	EM.792	Float	1
24	V.105 × 7E	Bottom Nut	1

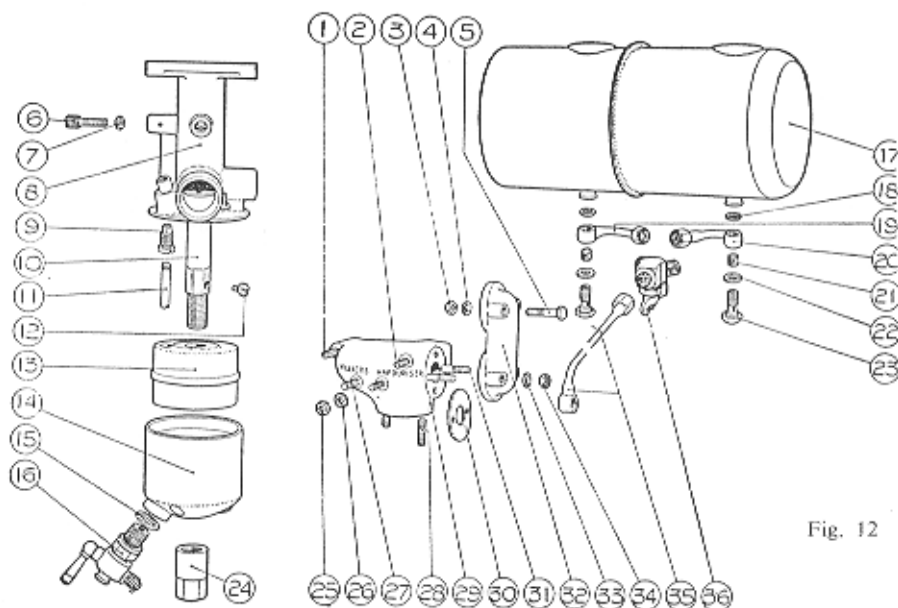

Fig. 12

SPECIAL PARTS FOR VAPORISING OIL ENGINES

See Fig. 12 for illustration references.

ITEM NO.	PART NO.	DESCRIPTION	QTY.
1	EM.816	Vaporiser Stud, short	1
2	E.4112	Vaporiser Stud, long	2
3	E.2539	Nut	2
4	E.1430	Washer	2
5	E.783	Silencer Bolt	2

ITEM NO.	PART NO.	DESCRIPTION	QTY.
14	EM.489	Float Cup ...	1
15	V.383E	Fibre Washer	} Type V Carburetter only
16	EM.1856	Drain Cock ...	
17	CM.1023	Fuel Tank (two compartments) ...	1
18	V.383E	Fibre Washer, small hole ...	2
19	EM.600	Fuel Pipe, short, (Vaporising Oil)	1
20	EM.601	Fuel Pipe, short, (Petrol) ...	1
21	V.404E	Gauze Filter for Banjo ...	2
22	H104 × 8	Washer, large hole ...	2
23	V.382E	Banjo Bolt ...	2
25	E.2539	Nut ...	6
26	E.1430	Spring Washer ...	6
27	EM.817	Manifold Stud ...	1
28	FG.185	Stud for Carburetter Flange ...	2
29	CM.813	Vaporiser, V Carburetter ...	1
—	CM.1884	Vaporiser, B.10 Carburetter ...	1
30	EM.821	Gasket ...	1
31	EM.819	Stud for Exhaust Pipe ...	2
32	DM.810	Exhaust Pipe (not fitted as standard)	1
33	E.2924	Washer for Exhaust Pipe ...	2
34	E.2539	Nut ...	2
35	DM.602	Fuel Pipe, long ...	1
36	EM.1857	Three-way Cock ...	1
—	Quote Engine No.	Carburetter complete ...	1
—	BM.1416	Cylinder Head (Mk.12 only) ...	1

OIL BATH AIR FILTER Type V Carburetter

Where an oil bath air filter is included in the specification, the following parts are used:—

Part No.	Description	Qty.
DM.1136	Strangler Elbow Assembly ...	1
DM.1646	Air Cleaner (replacing EM.487) ...	1
EM.1633	„ „ Pipe Assembly ...	1
1030 × 8E	„ „ „ Fixing Screw ...	1
EM.1174/1	Clip for Strangler Elbow ...	1
EM.1175	Screw for Clip ...	1
1002 × 15E	Nut for Screw ...	2
E.3222	Carburetter Fixing Bolt (replacing W.185) ...	2
M.2707E	$\frac{1}{8}$ " Shake-proof washer ...	1

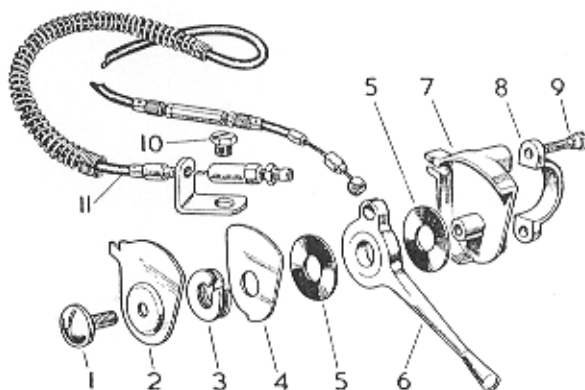

SLOW-RUNNING CONTROL. Fig. 13.

The following parts are fitted to some engines in place of the standard spring tension adjuster and anchor bolt.

ILLUS. NO.	PART NO.	DESCRIPTION	QTY.
1	V.117×5E	Screw, top cover	1
2	V.117×4E	Cover, top	1
3	V.117×8E	Washer, spring	1
4	V.117×6E	Plate, friction	1
5	V.117×7E	Washer, fibre, friction	2
6	V.117×2E	Lever, control	1
7	V.117×1E	Body, control ($\frac{7}{8}$ " dia. fixing)	1
— or	V.678E	Body, control (1" dia. fixing)	1
8	V.117×3E	Clip, control body ($\frac{7}{8}$ " dia. fixing)	1
— or	V.679E	Clip, control body (1" dia. fixing)	1
— or	V.162×1E	Plate, flat, control body fixing	1
9	V.754E	Screw, control body clip or plate fixing	2
10	E.1962	Screw, control bracket fixing	1
—	V.1699D	Control only (1" dia. fixing)	1
—	VC.112×3C	Control only ($\frac{7}{8}$ " dia. fixing)	1
11	Quote Engine No.	Cable only with bracket and adjuster	1

IDLING CONTROL

Engines to certain specifications are fitted with an idling control incorporating the following parts:—

1004×5E	Nut
EM.1990	Washer, fibre
EM.1959	Lever
EM.1973	Washer, steel
V.626E	Pin, pivot
EM.1958	Bracket (Type "V" carburetter)
EM.1964	Bracket (Type B.10 carburetter)

COMPONENT PARTS FOR KICKSTARTER

ILLUS NO.	PART NO.	DESCRIPTION	QTY.
—	DM.577/3	Crankcase Mk. 10 (Spigotted)	1
—	DM.1040	Crankcase Mk. 12 (Spigotted)	1
—	DM.1212	Crankshaft Mk. 10	1
—	DM.1302	Crankshaft Mk 12	1
—	CM.1208	Crankcase Adaptor Body (or Bracket) ...	1
—	CM.1209	Kickstarter Lever complete Assembly with Ratchet Plate and Rivets	1
—	E.363	Stud	4
—	E.364	Nut	4
—	E.1050	Washer, Spring	4
—	E.4150	Pivot Pin Washer	1
—	EM.1213	Kickstarter Pivot Pin	1
—	E.7224	Lever Return Spring... ..	1
—	E.7232	Return Spring Cap	1
—	EM.1242	Rubber Buffer	1
—	*EM.1218	Pulley, Single " V " 2 $\frac{3}{8}$ " dia.	1
—	E.5581	Key	1
—	EM.1221	Ratchet Pinion	1
—	E.7223/1	Ratchet Spring	1
—	E.7221/1	Ratchet Spring Cap	1
—	E.6552	Circlip	3
—	—	Set Screw " Unbrako " $\frac{1}{16}$ " B.S.F. $\times 4$ " ...	1

*Villers Standard. For " built-up " pulleys apply to manufacturer of equipment.

Note:—When kickstarter mechanism is fitted it is necessary for the petrol tank to be fixed on top of the Engine. See page 19 for details of components.

COMPONENT PARTS FOR ROTATING GAUZE

(Replacing Pulley CM.509 etc.)

—	EM.1751	Pulley Bolt	1
—	E.424	Spring Washer	1
—	EM.1750	Starting Pulley	1
—	DM.1748	Revolving Filter Gauze	1
—	D.7812/2	Dust Cover	1
—	EM.1752	Driving Peg	1

SILENCER WITH FLEXIBLE PIPE

PART NO.	DESCRIPTION	QTY.
—	Silencer, Burgess No. 2	1
EM.234	Pipe exhaust flexible 6 ft. with ferrule	1
DM.230	Adaptor, exhaust	1
EM.257	Stud, adaptor	2
E.2539	Nut	2
E.1430	Washer, spring	2
EM.202	Gasket, adaptor/cylinder	1
EM.307	Ferrule	1
—	Split pin and chain	1
VC.142 \times 5E	Screw	1
1002 \times 15E	Nut, screw locking	1

MAGNETO—continued from Page 24

ILLUS. NO.	PART NO.	DESCRIPTION	QTY.
46	R.56	Rotor, (flywheel), less fan	1
or 46	R.315	Rotor, (flywheel), with integral fan	1
		Items 1, 2, 3, and 47 are not used with this rotor.	
47	CM.508/2	Fan Rotor R.56 only	1
48	EM.571	Washer, copper	1
49	1002x13E	Washer, spring	1
50	M.1513E	Cheek, coil, left-hand	1
51	E.2924	Washer, plain, armature plate fixing screw	1
52	E.1430	Washer, spring, armature plate fixing screw	1

CARBURETTER B.10—continued from Page 28

OIL WETTED AIR CLEANER

ILLUS. NO.	PART NO.	DESCRIPTION	QTY.
39	V.1344D/1	Cover, filter	1
40	V.829E/1	Screw, clip retaining	1
41	V.1383D	Assembly, filter element	1
42	V.1349E	Clip, filter element	2

GOVERNOR LINKAGE, Etc.

45	V.626E	Screw, governor link pivot	2
46	1004x5E	Nut, pivot screw	2
47	EM.194	Link, governor lever/throttle lever	1
48	DM.1883	Lever, governor	1
49	E.3222/1	Bolt, governor lever	1
50	V.157x2E	Washer, governor lever bolt	1
51	E.2539	Nut, governor lever bolt	1
52	EM.2038	Circlip, governor crank	1
53	EM.1112	Bush, governor crank	1
54	EM.1918	Crank, governor	1
—	E.4011	Stud, inlet pipe	2

TOOLS, etc.

EM.548	Spanner, box, for flywheel centre nut	1
M.2715E	Screwdriver	1
M.2693E	Feeler gauge } For contact breaker adjustment	1
EM.556/7	Starting rope	1
D.5979	Spanner, spark plug	1
E.3815/6	Spanner, box, for fan nuts	1
Lodge CB.3	Spark plug	1
or Lodge SR.2	Spark plug, screened	1

TRACING TROUBLES

FUEL SYSTEM

Fault	Remedy
No petrol in tank.	Refill.
Petrol pipe choked.	Clean.
Filter gauze choked.	Clean.
Jet choked.	Remove obstruction by blowing out. WIRE MUST NOT BE USED.
Carburettor flooding.	Clean needle seating in carburettor body.
Incorrect use of strangler	See starting instructions.
Air cleaner choked.	Clean.

IGNITION SYSTEM

Fault	Remedy
Cut-out switch in " OFF " position.	Move to " RUNNING " position.
No spark at plug.	Clean and adjust. If still faulty try new plug.
Faulty ignition cable.	Examine for faulty insulation or loose connections and if necessary renew cable.
Contact breaker dirty or out of adjustment.	Clean and set points between .012" to .015" gap.
Timing slipped.	Re-time in accordance with instructions on page 9.

LACK OF COMPRESSION

Fault	Remedy
Cylinder head joints leak.	Tighten up cylinder head bolts if slack or renew gasket.
Valves not seating due to:—	
(a) Insufficient tappet clearance.	Adjust by grinding or filing end of valve stem.
(b) Valve stem sticking in guide.	Remove valve and clean off gum or carbon.
(c) Carbon on valve seat.	Remove valve and clean.
Leakage past piston due to:—	
(a) Piston rings sticking.	Remove and clean off carbon.
(b) Broken piston rings.	Replace.
(c) Worn cylinder bore.	Renew or rebore cylinder.

VILLIERS SERVICE REPLACEMENT AND REPAIR ORGANISATION

To enable users to obtain speedy servicing of Villiers Engine Units the following assemblies are obtainable through "Villiers" Officially Appointed Service Depots.

- (1) Engine Unit complete with magneto and carburetter.
- (2) Magneto complete with flywheel (less fan).
- (3) Carburetter (less air filter).
- (4) Rebored cylinder with oversize piston complete. (The cylinder presented for exchange must be suitable for re-boring to our maximum oversize of .030").
- (5) Genuine Villiers Spare Parts.

Prices and delivery details of replacement assemblies can be obtained from your nearest Service Depot, or direct from our Service Department, who will also be pleased to advise you of the nearest Villiers Service Depot for Industrial and Agricultural Engines.

Our Service Depots also carry comprehensive stocks of genuine Villiers Spares, and, in addition to carrying out the exchange service referred to above, are fully equipped to carry out complete overhauls of all types of Villiers Industrial and Agricultural Engines.

Should it be inconvenient for you to obtain your requirements from a Villiers Service Depot we are prepared to accept complete Engine Units and Sub-assemblies for repair or replacement. In this event the following points should be carefully noted.

ESTIMATES

If requested at the time of despatch, we are prepared to give an estimate before proceeding with any repair. This entails a certain amount of labour in dismantling to ascertain what new parts will be required, and therefore, in the case of any estimate not being accepted, a charge is made for our mechanic's time in taking down the engine for report and the re-building, and return carriage costs.

Estimates must be treated as approximate only. We reserve the right to include additional parts should these be found, on further examination or on bench test, to be necessary, to make the repair satisfactory.

We do not undertake to fit to engines sent to us for overhaul, such parts as specified by the customer if we consider that other parts are necessary to make an efficient repair. In such cases, we are prepared to supply the customer's requirements in spares, but we do not undertake to fit them.

IMPORTANT

1.—In correspondence, and when ordering replacement assemblies or spares, always quote the Engine Specification and Serial Number stamped on the plate attached to the engine cowling. This is most essential as there are minor changes from standard in many engines supplied for various purposes. The parts listed in this booklet relate to standard engines only.

The number is comprised of two parts, the first being the SPECIFICATION Number which is the key to the component parts fitted, and the second being the Engine Serial Number by which the date of manufacture, etc., can be determined, e.g. 522/12345.

The **Magneto** also bears a SPECIFICATION Number (example: R.56/A.55) but no Serial Number. The "R" (Rotor or Flywheel), and "A" (Armature Plate) Number is stamped on the Flywheel.

The **Carburettor** bears no identification marks.

2.—When sending parts for replacement, repair, or as pattern, the name and address of the sender should always be securely attached, and full instructions explaining what is required must also be sent separately by post. In no circumstances should instructions be sent only with the parts as they are liable to be lost or damaged in unpacking.

3.—If an engine is sent for repair, it should be well packed in a strong wooden box. Cardboard or a sack is insufficient, and engines so packed are liable to get seriously damaged in transit. Packing cases are not returnable unless specially asked for by the owner at the time of sending to us.

4.—All goods must be consigned to us carriage paid, addressed to "Service Dept." Goods returned by rail are consigned carriage paid.

5.—As we are not manufacturers of complete vehicles or other machines, **only the engine, magneto and carburettor should be sent to us.** If machines are forwarded an extra charge will be made for dismantling the engine from the frame and returning the components that are not of our manufacture.

6.—We prefer to bench test every repaired engine before returning it to its owner. It is, therefore, always advisable to send the engine complete with its magneto, sparking plug and carburettor.

7.—When forwarding a flywheel magneto for overhaul, send the armature plate and the flywheel complete.

8.—Any engine or sub-assembly sent to our Works for repair and not paid for within 12 months from the date of our estimate or from the date the owner is notified of completion of repair, will be dealt with under The Disposal of Uncollected Goods Act, 1952.

9.—An extra amount must always be included in remittances to cover the cost of postage or carriage and packing on spare parts. This is 5% extra up to £10 value. Minimum extra is 1/-. Stamps cannot be accepted for items over 1/- in value.

10.—When making remittances by telegraph money order, the name and address of the sender must be included in the space provided on the Post Office Requisition Form for a private message from remitter to payee. Unless this is done, the Post Office does not give this information upon the telegram.

GUARANTEE

WE give the following guarantee with VILLIERS Engines and Accessories in place of any implied guarantee by statute or otherwise, all such guarantees being in all cases excluded. No statement or representation contained in this catalogue shall be construed as enlarging or varying this guarantee. In the case of engines and accessories which have been used for " hiring out " purposes, or from which our trade mark, name, or manufacturing number has been removed, no guarantee of any kind is given or is to be implied.

We guarantee, subject to the conditions mentioned below, that all precautions which are usual and reasonable have been taken by us to secure excellence of materials and workmanship, but this guarantee is to extend and to be in force for six months only from the date the engines or accessories are despatched by us, and the damages for which we make ourselves responsible under this guarantee are limited to the replacement of a part manufactured by us which may have proved defective.

We cannot accept responsibility for the replacement of any proprietary articles or parts not manufactured by us, unless the makers of these parts agree to replacement.

We do not undertake to refit or bear the cost of replacement or refitting such new part. We guarantee, subject to the conditions mentioned below, to make good at any time within six months any defects in these respects. As VILLIERS Engines and Accessories are liable to derangement by neglect or misuse, this guarantee does not apply to defects caused by wear and tear, misuse and neglect.

CONDITIONS OF GUARANTEE

If a defective part should be found in our engines or accessories, it must be sent to us carriage paid and accompanied by an intimation from the sender that he desires to have it repaired free of charge, under our guarantee, and he must also furnish us at the same time with the number of the engine, and full particulars of purchase. Failing compliance with the above, no notice will be taken of anything that may arrive, but such articles will lie here at the risk of the sender, and this guarantee or any implied guarantee shall not be enforceable.

THE TERM " AGENT " is used in a complimentary sense only, and those firms whom we style our agents are not authorised to advertise, incur any debts, or transact any business whatsoever on our account other than the sale of goods which they may purchase from us, nor are they authorised to give any warranty or make any representations on our behalf or sell subject to or with any conditions other than those contained in the above guarantee.

The guarantee becomes void if any parts not made or supplied by THE VILLIERS ENGINEERING COMPANY, LTD., are fitted to a VILLIERS engine. To safeguard his own interests, the owner should always insist upon genuine VILLIERS parts.

NOTES

NOTES

S P A R E P A R T S L I S T S

Air Filter (Oil Bath Type) Type V Carburetter	31
Carburetter (Pilot Jet)	30
Carburetter Type V	26
Carburetter B.10	28, 34
Engine, Cowl and Tank Assembly	16 to 19
Governor Gear	23
Kickstarter	33
Magneto	24, 34
Petrol/Vaporising Oil Engines	30
Reduction Gears (3: 1 and 6: 1)	22
Rotating Gauze	33
Slow-running control	32
Silencer with Flexible Pipe	33
Tools	21

L I S T O F I L L U S T R A T I O N S

	Fig. No.	Page
Carburetter, Type V, Adjustment	4	12
Carburetter, Type V, Parts	10	27
Carburetter B.10	11	29
Carburetter, Pilot Jet, Adjustment	4A	13
Carburetter, Pilot Jet, Parts	12	30
Carburetter, Petrol/Vaporising Oil, Parts	12	30
Connecting Rod	2	10
Contact Breaker Assembly	5	15
Engine, General View	—	Frontispiece
Engine, Cowl and Tank Assembly	6	20, 21
Governor Gear, Parts	6	18, 19
Magneto Parts	9	25
Reduction Gear Parts (3: 1 ratio)	7	23
Reduction Gear Parts (6: 1 ratio)	8	23
Reduction Gear Lubrication 3: 1	1	7
Reduction Gear Lubrication 6: 1	1A	7
Slow-running controls	13	32
Valve, Timing	3	11

at ..

Villiers

*The Power and the Heart
of a fine machine*

... ..